

DRILL 19 DIA IN PIPE TO SUIT SOCKET

DETAIL B
SCALE 1 : 5

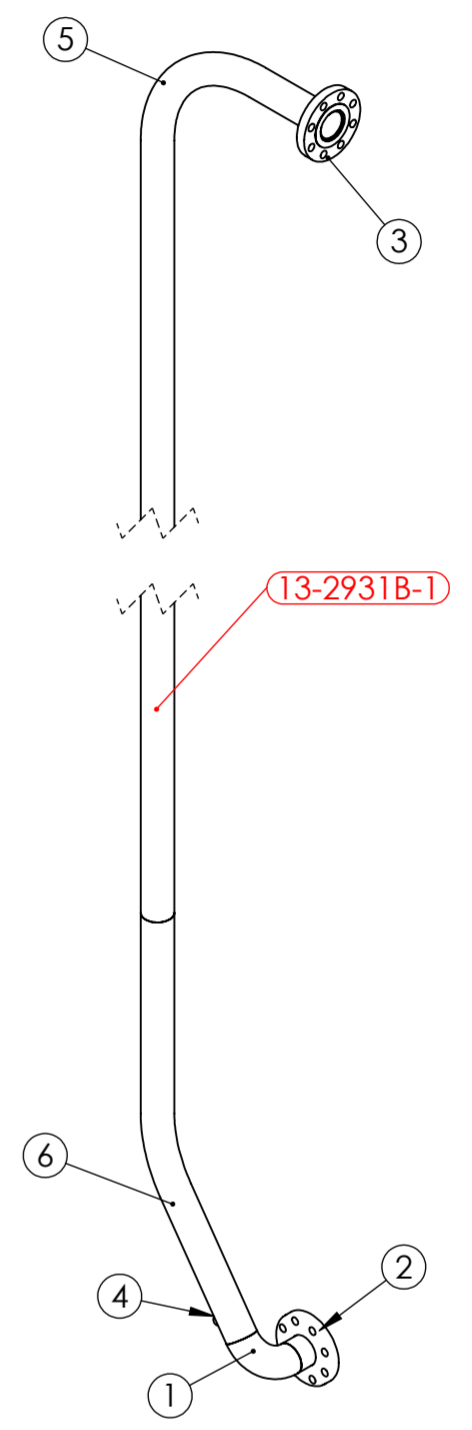

PIPE LABEL - 13-2931B-1

ISSUED FOR CONSTRUCTION 4/11/25
REQUIRES PLANNING & SITE INTERACTION

ITEM	DRAWING No	DESCRIPTION	QTY.	MASS (kg)
1	OEM-80-LR-40-316L	80NB LONG RADIUS BEND SHED 40 316L S/S	1	2.06
2	OEM-80NB-JIS30K-P-316L	80NB PLATE FLANGE JIS 30 K 316L S/S	1	5.32
3	OEM-80NB-300-SF-316L	80NB - 300lb SLIP ON FLANGE 316L S/S	1	6.08
4	OEM-1_2-BSPP-3000-316L	1/2 BSPP 3000 Lb HALF COUPLING 316L S/S	1	0.06
5	J003435-69	80NB SHED 40 PIPE x 90 DEGREE BEND 400R	1	43.36
6	J003435-56	80NB SHED 40 PIPE x 145 DEGREE BEND 375R	1	17.63
7	13-2931B-1-1	80NB SHED 40 PIPE 316 S/S	1	0.81

RED EYE
QR CODE
AREA

PIPEWORK MANUFACTURED OF A JIG - FLANGES AS PER DRAWING DIMENSIONS ARE APPROXIMATE

UNIT 13 VALVE 2931B PIPE 1 WEIGHT - 65.49 kg

REV	NAME & DATE	DESCRIPTION	UNLESS OTHERWISE SPECIFIED: TOLERANCES: MACHINE + / - 0.25mm FABRICATION + / - 1.0 mm		DRAWN N DE BRUYN 19/09/2025	DRAWING CHECKED	
			THIS DRG SUPPLIED BY RODDY ENGINEERING 14 Waratah St, TUMUT NSW 2720 Ph: 02 6947 4039		DESIGNED	DESIGN CHECKED	
			DRAWING No. 13-2931B-1	REV:	SCALE 1:10 WORK ORDER No	APPROVED	SMA-DRG-NO
					SECTION No/KKS	A2 SHEET SIZE	