

ITEM NO.	QTY.	DESCRIPTION	LENGTH
1	1	42x3 CHS	736
2	1	42x3 CHS	768
3	1	42x3 CHS	927
4	1	42x3 CHS	436

DIMENSIONS IN MILLIMETRES

ITEM	DWG No	PART No	DESCRIPTION	QTY.
1	3467-95-15-10		GATE FRAME 980H x 770 CTS	1
2	OEM-32NB-SRB		32NB SHORT RADIUS BEND	3

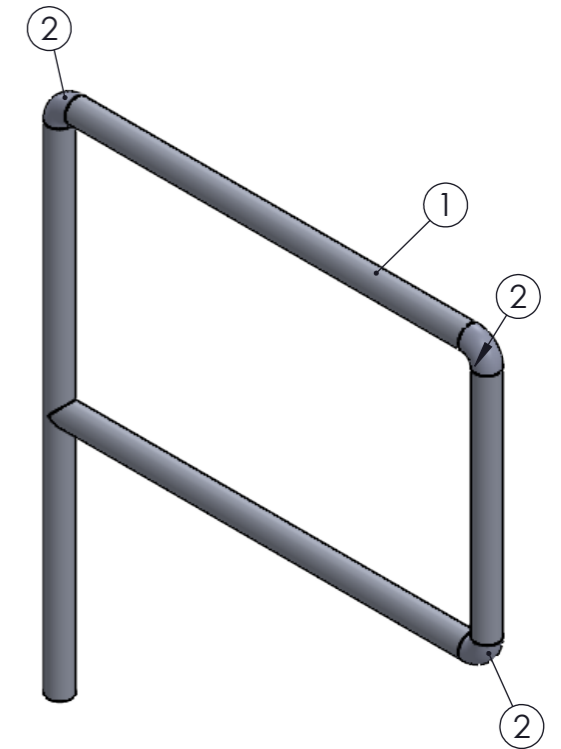
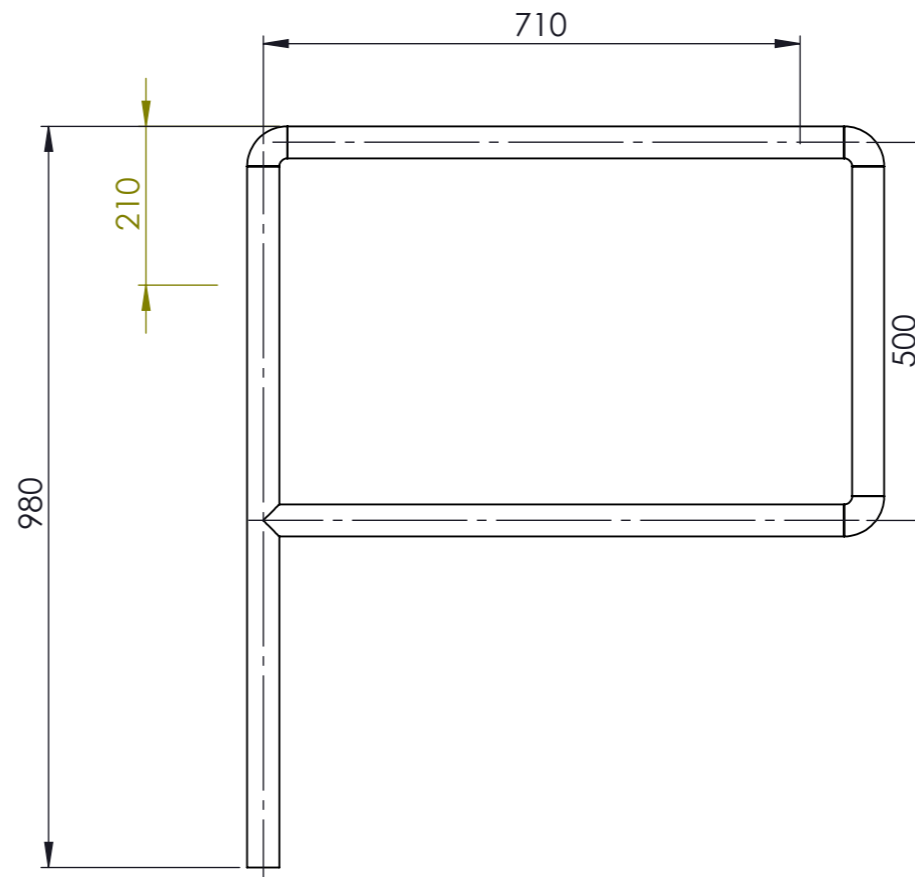
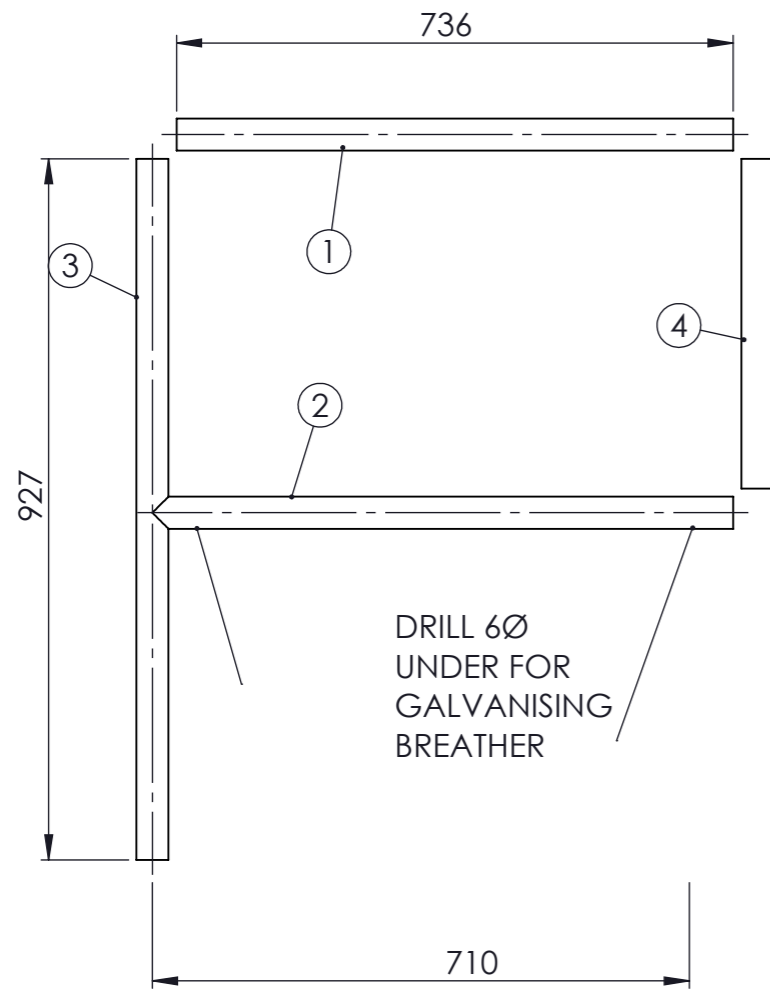

ALL WELDS - 4CFW UNLESS NOTED OTHERWISE
FINISH - HOT DIPPED GALVANISED

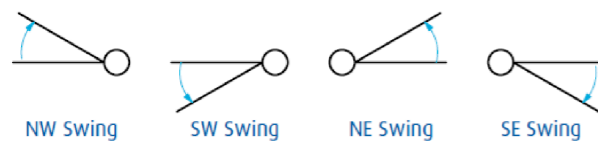

UNLESS OTHERWISE SPECIFIED: TOLERANCES: MACHINE + / - 0.25mm FABRICATION + / - 1.0 mm

THIS DRAWING IS THE PROPERTY OF MECHANICAL ENGINEERING & CAD SERVICES (MECS) Pty Ltd & MUST NOT BE MANUFACTURED FROM, COPIED OR TRANSMITTED TO A THIRD PARTY WITHOUT THE PRIOR APPROVAL FROM MECHANICAL ENGINEERING & CAD SERVICES (MECS) Pty Ltd

MECS
Mechanical Engineering & CAD Services
11 Campbell Place WAGGA NSW 2650
Ph: - 0409 985 816
Email: nick@mecservices.com.au

DIMENSIONS IN MILLIMETRES

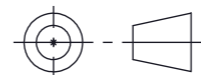

THIRD ANGLE PROJECTION

CLIENT

RODDY ENGINEERING

14 Waratah St TUMUT NSW 2720
Ph: - 02 6947 4039
Email: roddyeng.com.au

TITLE:

**SAFETY GATE NE SWING 980H
800 CTS**

DWG NO. 3467-95-15

REV

A3

DRAWN N DE BRUYN

DATE 7/12/2020

SCALE:1:10

SHEET 1 OF 1