

DIMENSIONS IN MILLIMETRES

ITEM NO.	DESCRIPTION	LENGTH	QTY	MASS (kg)
1	60x3.9 CHS	2280	1	12.61

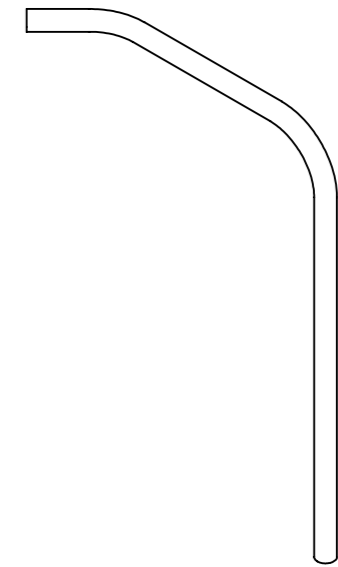
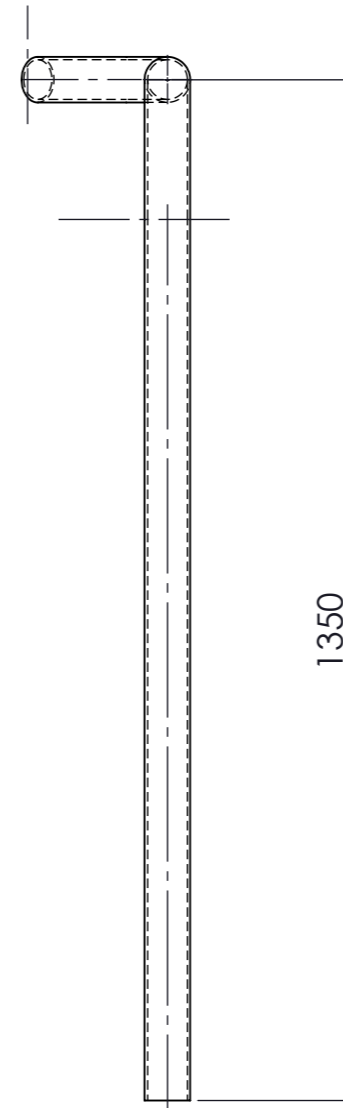
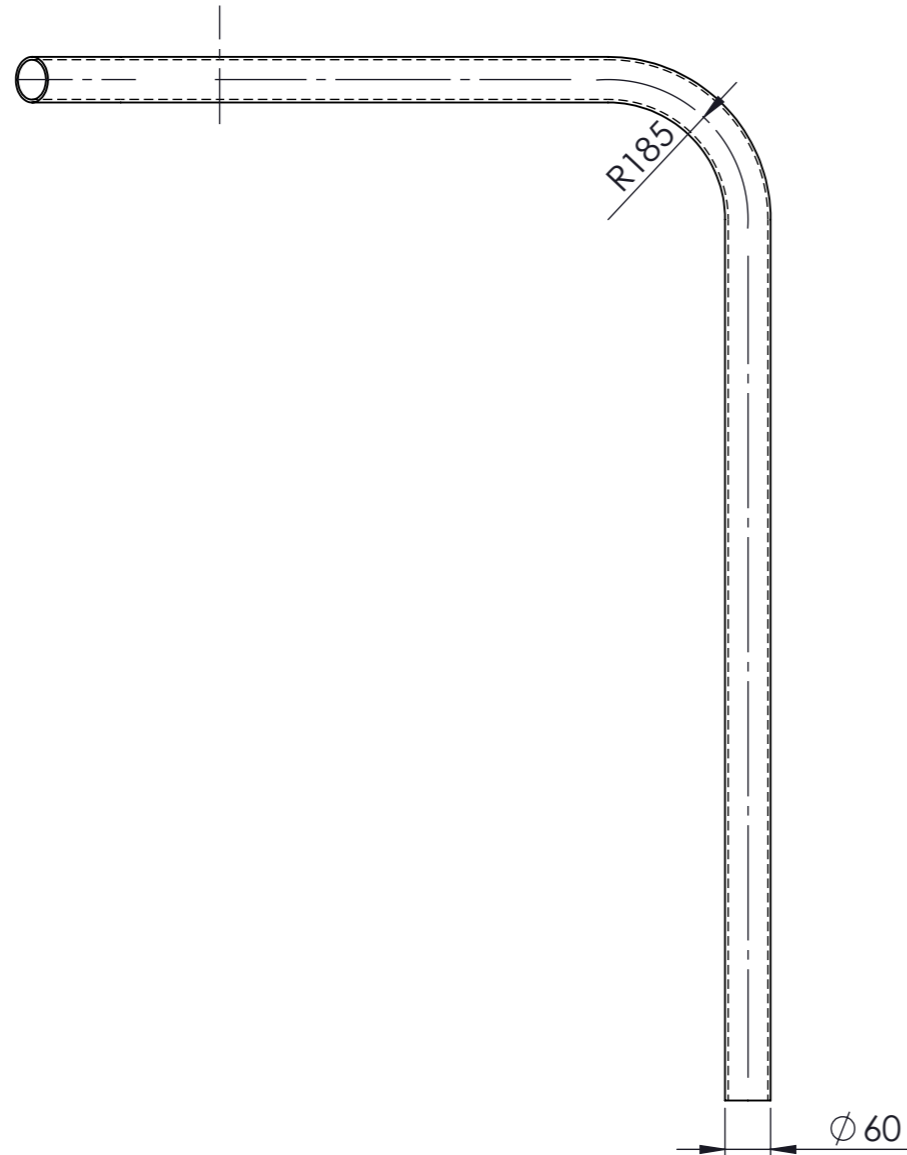
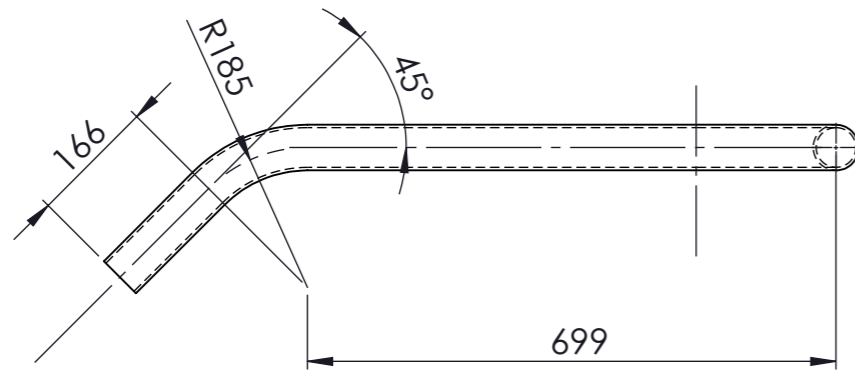

MATERIAL:- 316L STAINLESS STEEL

50NB SHED 40 PIPE BENT VALVE 2905 PIPE 2 WEIGHT - 12.61 kg

UNLESS OTHERWISE SPECIFIED: TOLERANCES: MACHINE + / - 0.25mm FABRICATION + / - 1.0 mm

DIMENSIONS IN MILLIMETRES

CLIENT

TITLE: 50NB SHED 40 PIPE BENT VALVE 2905 PIPE 2

THIS DRAWING IS THE PROPERTY OF MECHANICAL ENGINEERING & CAD SERVICES (MECS) Pty Ltd & MUST NOT BE MANUFACTURED FROM, COPIED OR TRANSMITTED TO A THIRD PARTY WITHOUT THE PRIOR APPROVAL FROM MECHANICAL ENGINEERING & CAD SERVICES (MECS) Pty Ltd

MECS
Mechanical Engineering & CAD Services
 11 Campbell Place WAGGA NSW 2650
 Ph: - 0409 985 816
 Email: nick@mecservices.com.au



THIRD ANGLE PROJECTION

RODDY ENGINEERING

14 Waratah St TUMUT NSW 2720
 Ph: - 02 6947 4039
 Email: roddyeng.com.au

DWG NO. J003435-62

REV A3

DRAWN N DE BRUYN DATE 27/03/2024 SCALE:1:10 SHEET 1 OF 1