

**PROFILE CUT DIMENSIONS**

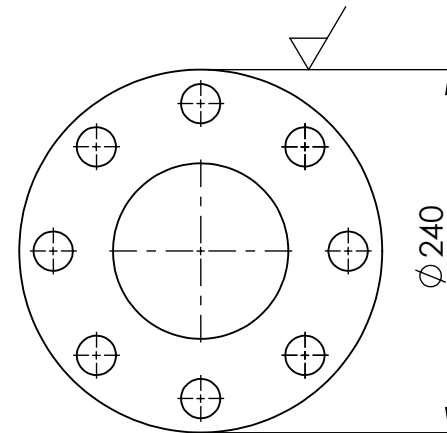

**AFTER MACHINING**

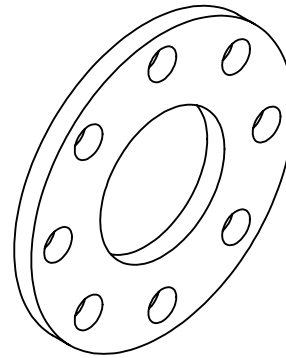
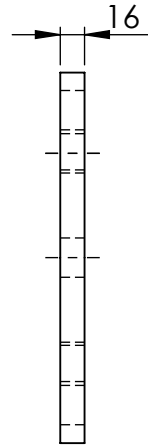
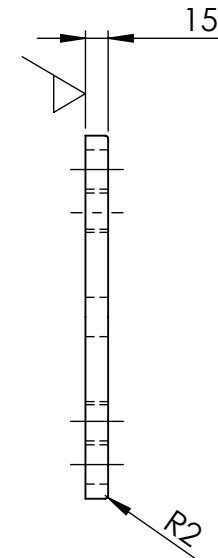

**MATERIAL:- 316L STAINLESS STEEL**

UNLESS OTHERWISE SPECIFIED: TOLERANCES: MACHINE +/- 0.25mm FABRICATION +/- 1.0 mm

DIMENSIONS IN MILLIMETRES

CLIENT

TITLE:

THIS DRAWING IS THE PROPERTY OF MECHANICAL ENGINEERING & CAD SERVICES (MECS) Pty Ltd & MUST NOT BE MANUFACTURED FROM, COPIED OR TRANSMITTED TO A THIRD PARTY WITHOUT THE PRIOR APPROVAL FROM MECHANICAL ENGINEERING & CAD SERVICES (MECS) Pty Ltd

**MECS**  
**Mechanical Engineering & CAD Services**  
 11 Campbell Place WAGGA NSW 2650  
 Ph: - 0409 985 816  
 Email: nick@mecservices.com.au

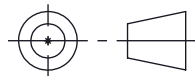

THIRD ANGLE PROJECTION

WEIGHT: 4 kg

**RODDY**  
**ENGINEERING**

14 Waratah St TUMUT NSW 2720  
 Ph: - 02 6947 4039  
 Email: roddyeng.com.au

**100NB PLATE FLANGE JIS30K - 316L S/S**

DWG NO. **J003435-72**

REV

**A4**

DRAWN N DE BRUYN

DATE 15/11/2024

SCALE:1:5

SHEET 1 OF 2